



TABLE OF CONTENTS

| | |
|---|----|
| INSTALLATION PREPARATION..... | 2 |
| Parts Supplied..... | 2 |
| Accessories..... | 2 |
| Installation Overview..... | 2 |
| Alternative Transducers and Mounting Methods..... | 4 |
| Transducer Exchange..... | 5 |
| INSTALLATION..... | 6 |
| Transom Installation..... | 6 |
| Inside the Hull Installation..... | 10 |
| Control Head Installation..... | 12 |
| Test the Installation..... | 15 |
| INTRODUCTION..... | 16 |
| USING THE LCR 4000..... | 19 |
| Total Screen Update®..... | 19 |
| Operational Instructions..... | 21 |
| Learning to Use Your LCR..... | 29 |
| Learning to Read the Display..... | 31 |
| MAINTENANCE AND WARRANTY..... | 34 |
| Maintenance..... | 34 |
| Troubleshooting..... | 35 |
| Warranty..... | 38 |
| Service Policy..... | 39 |
| Customer Support..... | 40 |

TRANSDUCER MOUNTING PROCEDURE

Humminbird's high-speed transducer is supplied with your LCR. This transducer has been designed to give good high speed readings on most all boat designs, including aluminum.

Please carefully consider the following before installing your transducer.

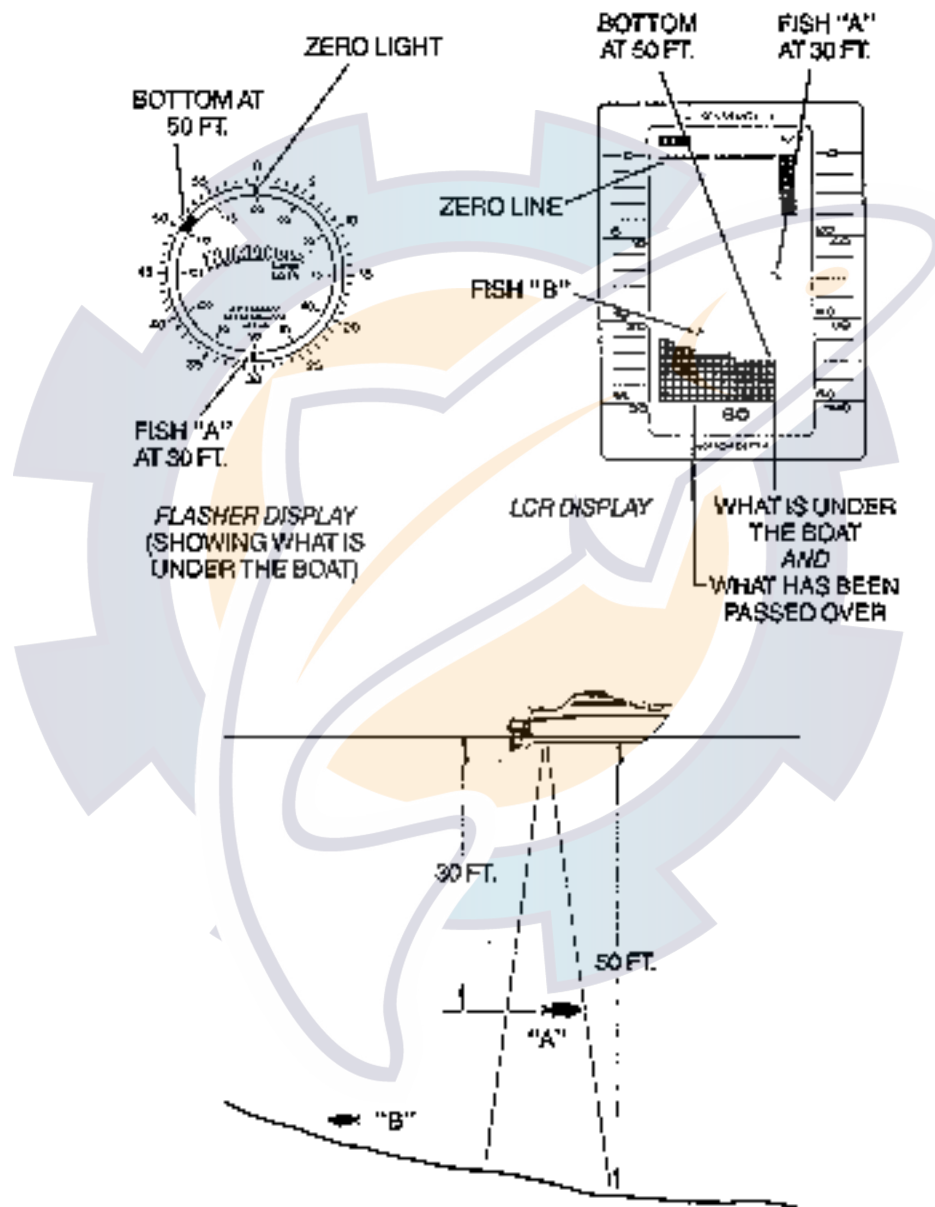

FIGURE 1

TRANSDUCER MOUNTING OPTIONS

A. Transom Mount- The Humminbird high speed transducer allows the transducer element to be mounted below the bottom of the boat hull keeping the transducer out of turbulent water and insuring good high speed operation. The transducer will

absorb the blow of any obstruction by rotating up out of the metal spring bracket without harming the transducer, or your boat. The transducer can be re-engaged by simply rotating the transducer down and snapping it back in place. (See Figure A)

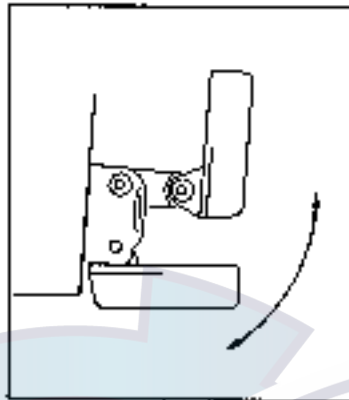

Figure A

- B. Inside Hull Mount- The high speed transducer can be mounted inside the hull (without pivot assembly) using the proper two-part epoxy, such as Humminbird's epoxy kit. Even though there is some loss of signal in shooting through the hull, your LCR will perform well with this type of installation. You cannot shoot through the hull of an aluminum boat.
- C. Trolling motor Mount- This type of transducer is not supplied with your LCR. It is designed to mount on the foot of a trolling motor. You may exchange your un-used high speed transducer for a trolling motor transducer. Call the Humminbird Customer Service Department.
- D. Bronz Thru-Hull Mount- This transducer is not supplied with your LCR but for an additional cost you may exchange your un-used high speed transducer for a bronz thru-hull. The bronz thru-hull transducer has a threaded stem which installs through a hole drilled in the boat hull, leaving the housing exposed under the boat. This type of installation must be used for many boats with in-board engines, because there is no suitable location on the transom away from the noise and turbulence created by the prop. A bronz thru-hull transducer should be installed by qualified personnel only.

The LCR will operate well at high speeds with a properly mounted transducer. Remember, a transducer will not work transmitting through air or through air bubbles.

1. TRANSOM MOUNTING PROCEDURE

Step 1.

MOUNTING LOCATION- It is important that the transducer be mounted on the transom where water flow is in constant contact with the transducer. You may wish to observe the rear of the boat while it is moving through the water to determine the best mounting location.

Step 2.

BRACKET INSTALLATION (Aluminum Boats)- To install the metal bracket on an

aluminum boat locate the template on the transom between rows of rivets, or ribs that are on the bottom of the boat. Align the template so that the bottom corner of the template nearest the center of the transom is on the bottom edge of the transom.

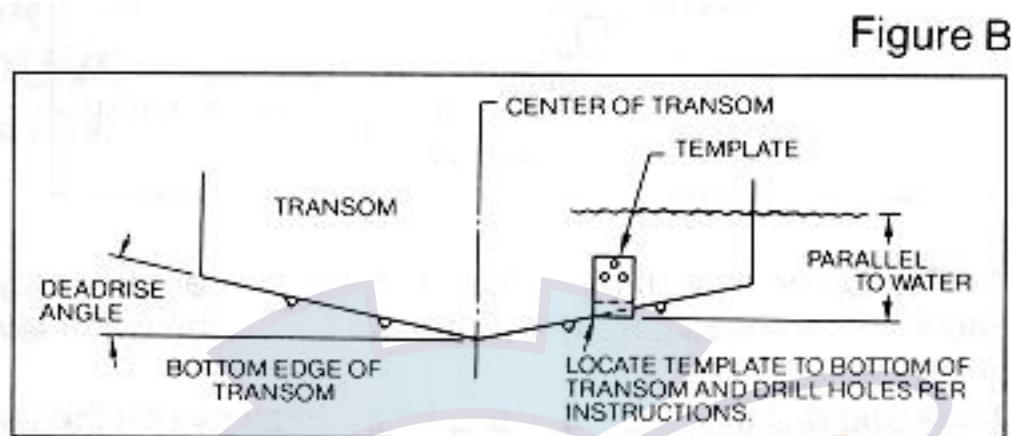

Once the location is determined mark and drill three 7/64" dia.. holes noted on the template. Attach the metal bracket using three #10 self threading screws supplied. Be sure to align holes in the center of the Bracket slots. On some aluminum boats it may be necessary to use a wood back-up plate. It is important to use a silicone sealant between the screwhead and bracket in order to prevent leaking. (See Figure C)

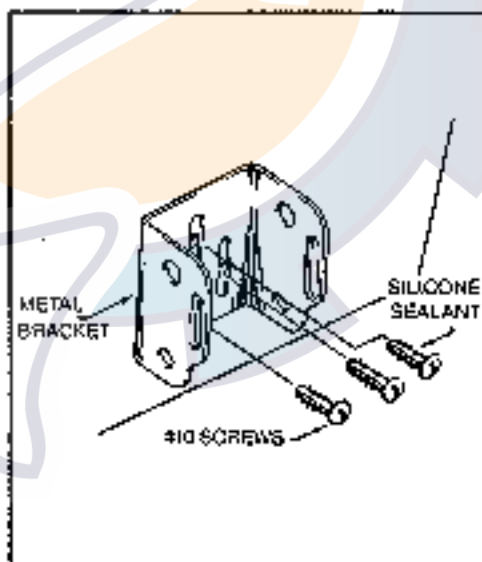
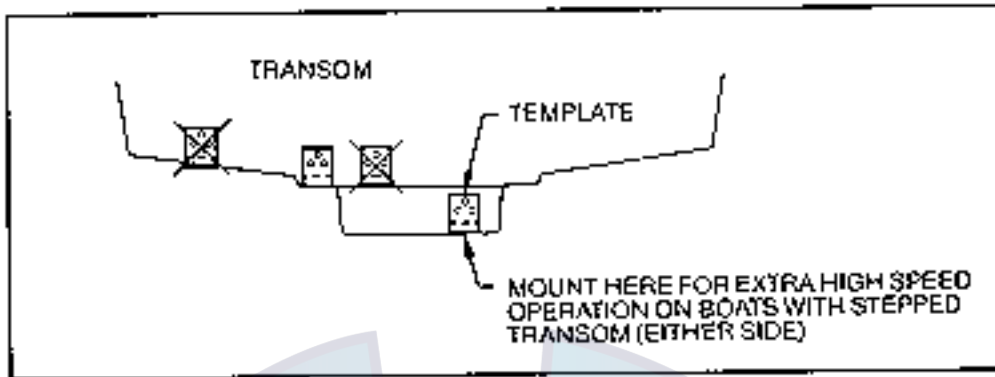

Figure C

Step 2.
BRACKET INSTALLATION (Fiberglass Boats)- If your boat has a stepped transom located below and under the main transom, the compact transducer design allows mounting in this area. This mounting location is recommended for good reading at very high speeds. (See Figure D)

To install the metal bracket on a fiberglass boat, locate the template on the transom in the same manner as for an aluminum boat. (See Figure C)

Figure D



NOTE: On boats with more than 15 degree deadrise angle it may be necessary to mount the transducer slightly off parallel with the water level. (See Figure E)

Mark and drill the three 9/64" dia. holes as shown on the template. Attach the metal bracket using the three #10 self threading screws supplied. Be sure to align the holes so that they are centered vertically in the three slots found in the bracket. It is important to use a silicone sealant between the screwhead and bracket in order to prevent leaking.

Figure E

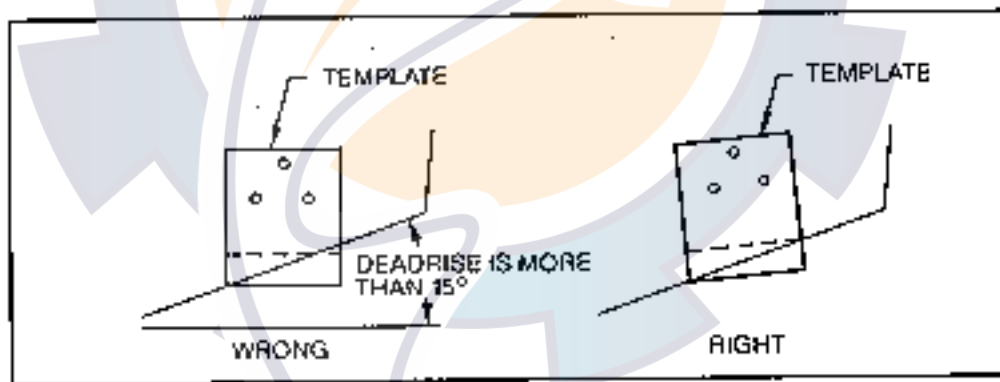

Step 3.

TRANSDUCER PIVOT ASSEMBLY- Assemble the pivot to the transducer main body using the two 1/4"x5/8" allen head screws, two 3/8" tooth washers and two, 1/4" square nuts. Make sure the tooth washers are sandwiched between the transducer main body and the pivot. The square nuts are trapped inside the pivot and will not rotate as the allen head screws are tightened. HOWEVER, DO NOT TIGHTEN AT THIS POINT. (See Figure F)

CAUTION: DO NOT APPLY LOCTITE® OR SIMILAR LOCKING COMPOUNDS BECAUSE THEY WILL ATTACK THE PLASTIC.

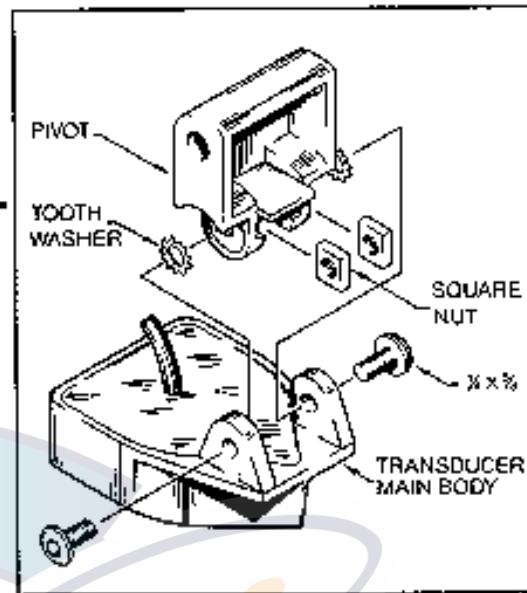

Figure F

Step 4
TRANSDUCER ASSEMBLY- Insert the transducer assembly into the metal bracket from the bottom. Push up until the holes in the plastic pivot align with the uppermost holes in the bracket. Slide the O-ring on to the headed pin and insert it through the two parts. Assemble by screwing the 1/4"x3/8" allen head screw into the end of the pin and tighten. (See Figure G)

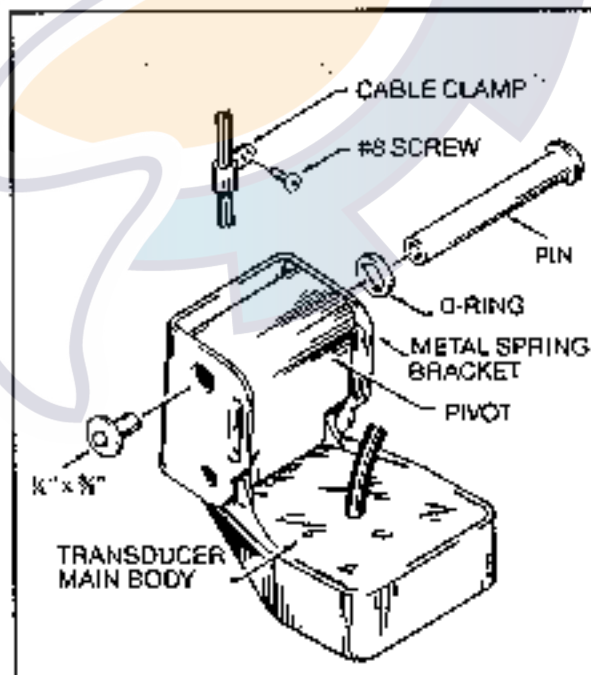
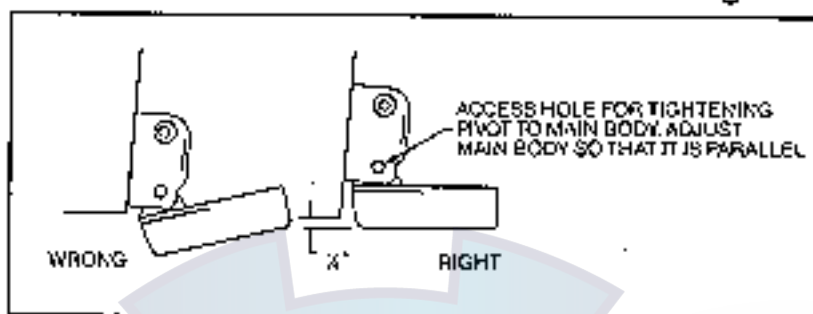

Figure G

Step 5
ANGLE ALLIGHMENT- Set the transducer angle so that it is parallel with the bottom of the boat hull. Once proper alignment is achieved, tighten the two allen head screws

using the 5/32" allen wrench provided. The screws are visible through the access holes on each side of the metal bracket. Check to make sure the transducer main body is rigidly fastened to the pivot. (See Figure H)

Figure H



Step 6

CHECK POSITION OF TRANSDUCER- At this point, check to see that the bottom of the transducer is a minimum of 1/4" below the bottom of the transom. (However, as noted in STEP 2, the top of the transducer cannot fall below the bottom of the transom). If it is not, remove the transducer assembly from the metal bracket by removing the pin installed during STEP 3. Loosen the metal bracket mounting screws, re-position the bracket utilizing its slotted holes, tighten and re-assemble. It may be necessary to replace the silicone sealant after this adjustment is made.

NOTE: It may be necessary to make several high speed runs to adjust transducer either UP/DOWN or to re-adjust the angle to achieve optimum results.

Step 7

CABLE CLAMPS- Install cable clamps as necessary by drilling a 1/8" dia. hole for the # 8 screw supplied.

2. INSIDE HULL MOUNTING PROCEDURE

Warning: In order to achieve proper results with this type installation, it is important that the transducer be mounted by someone familiar with the use of two part epoxy adhesives. For this reason, Techsonic Industries, Inc. will not be responsible for any damage due to the mounting of your transducer in this manner.

NOTE: An Epoxy Kit (Part N. EPK) is available from Humminbird. This Epoxy Kit has been formulated for Inside Hull Transducer Installation.

1. Select as flat an area as possible near the aft end and center of boat where the hull is thin and not double. If the bottom has a runner down the center of boat, select an area to one side of the runner, but as close to the runner as possible.
2. Clean the inside of the boat with lacquer thinner in the area transducer is to be mounted. Outside of boat in this area should also be cleaned. (Not with lacquer thinner).
3. Put approximately one inch of water in the bottom of the boat.

4. Put transducer in the water. The bottom of the transducer should be in a flat area and should be in good contact with the bottom of the boat.
5. Operate the LCR with the boat operating at high speed. The transducer may have to be moved in order to find an area where satisfactory operation is observed.
6. When an area is found that produces satisfactory operation, mark the location of the transducer.
7. Remove the water and transducer and clean the marked area and the bottom of the transducer thoroughly.
8. Using the Humminbird Epoxy Kit or equivalent, mix an ample amount of epoxy without causing it to bubble and pour it in the area the transducer is to be mounted. The puddle should be larger than the bottom of the transducer.
9. Coat the bottom of the transducer with epoxy, then put it in the center of the puddle and push down on the transducer while moving it around in a circular motion. This forces out any air bubbles that may be trapped between the bottom of the transducer and the hull of the boat.
10. Let epoxy cure then the transducer is ready to operate. No water is now required in the bottom of the boat and gas and oil that is spilled inside of the boat will not degrade performance as it will if the transducer is placed only in water.
CAUTION: Do not use the silicone seal or any soft adhesive to bond the transducer to the hull. This will reduce the sensitivity of the unit.

CAUTIONS

1. Occasionally the “eye” of your transducer may become dirty from storage or from contact with oils present in boats or marina environments. (Oil will cause the “eye” to lose the intimate contact with the water which is necessary for efficient operation.) The “eye” may be cleaned with liquid detergent.
2. Improper installation of the transducer can alter the efficiency and accuracy of the entire system.
3. If your boat or transducer is out of the water for a period of time, it may take a short period of time for the transducer to become thoroughly “wetted” when returned to the water. Also, re-entry may cause turbulence, which will create air bubbles in the “eye” of the transducer. The bubbles will disappear in a short time or can be removed by rubbing the transducer “eye” with your fingers while the transducer is in the water.
4. If your instrument should fail to function, be sure to check all the electrical connections before removing the transducer or calling a serviceman.
5. Inspect your transducer cable and make sure that it has not been cut or damaged to the point where it will affect the performance of the transducer. A slight nick or cut, exposing the outer cable, can be repaired by wrapping with electrical tape. A transducer can be damaged if the inner cable and outer cable are allowed to make contact. Such a problem can sometimes be corrected by properly splicing the coaxial cable. This should only be attempted by a qualified service technician.
6. If your LCR is not working properly and you suspect the problem might be in your transducer, we would recommend you borrow a unit from a friend and try it on your boat. If the symptoms are the same, you can almost be certain that the problem is in the transducer.

INSTALLING THE LCR

The LCR should be mounted on a flat, solid surface for maximum stability. The low profile swivel mount has four holes drilled in the base. It is recommended that all four holes be used.

Position the swivel base and drill four ¼" diameter holes. Note: The LCR hole pattern is the same as for all Humminbird flasher units. Use hardware provided to mount this base to the boat.

Next place the gimbal bracket on the swivel base and attach with four small machine screws, provided.

Place the LCR in the gimbal mount and make certain the rubber washers provided are placed between the unit and the gimbal bracket. Important: Note which side of the gimbal faces forward. (Slots on gimbal bracket go towards rear). Also, rubber washer must be located between the unit and the gimbal bracket.

Install the mounting knobs and tighten snugly. The unit can now be swiveled and tilted to any desired position.

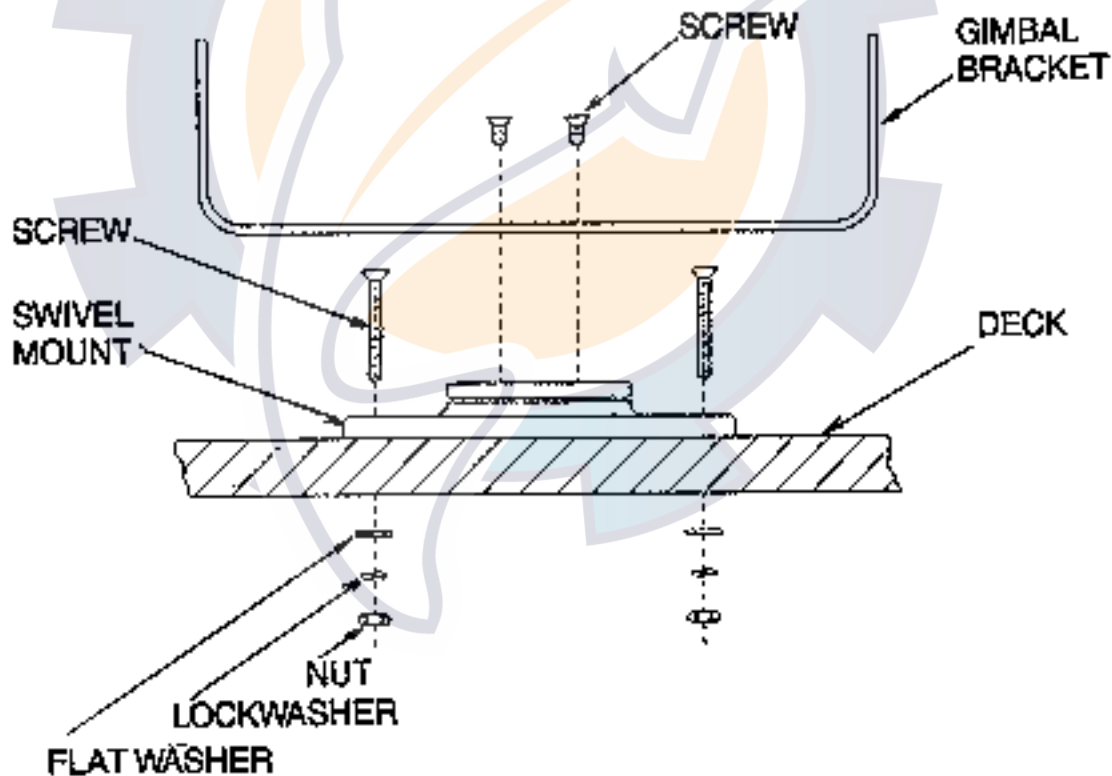

FIGURE 9

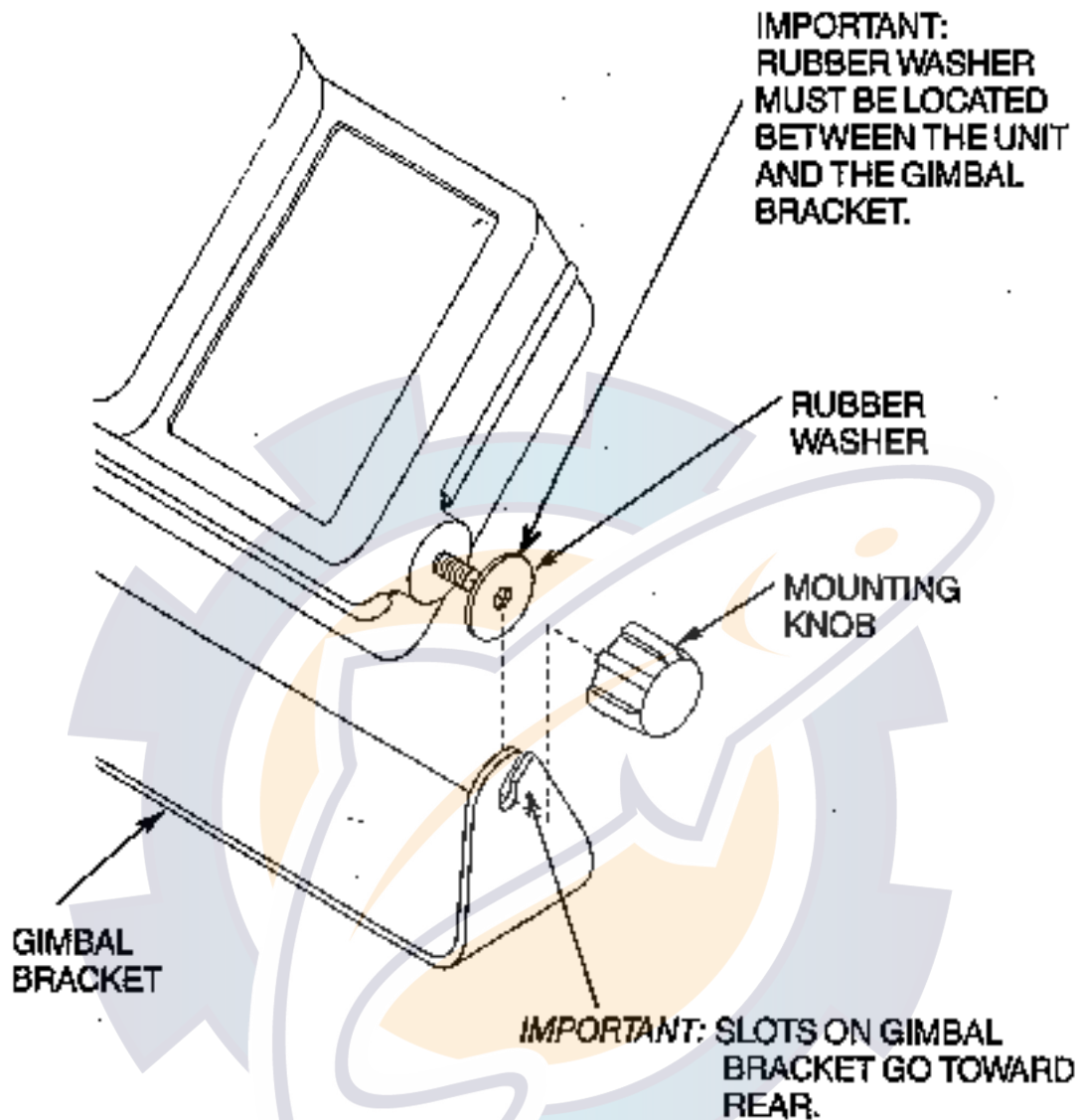

FIGURE 10

OTHER MOUNTING OPTIONS

1. The LCR gimbal bracket can also be mounted on the SM-4, quick disconnect swivel mount.
2. The LCR gimbal bracket can also be mounted directly to the dash without the swivel mount, however, this method is not recommended since the unit cannot be rotated.

INSTALLING THE CABLES

Your LCR comes equipped with Humminbird's new Angle-Lock power and transducer connectors. The power connector is identified with the letter P on the back of the plug. It plugs into the outlet on the back of the unit marked "Power". The transducer connector is identified with the letter T and plugs into the outlet on the back of the unit marked

“Transducer”. Note: An adapter (AD-4) is available to allow use of an old waterproof (BNC) transducer with the LCR, but be sure that the transducer is a 16-degree. A 32-degree transducer cannot be used.

A 1 1/8” hole must be drilled to pull through the transducer connector. After drilling the hole, pull the transducer connector up through the hole. If you are installing two units, both transducer connectors can be pulled through this 1 1/8” inch hole. Next, push the power cable wires down through the hole. A hole cover has been provided which will dress and hold the wires. Install the hole cover after determining the necessary wire length from the hole.

The power cable has a red lead to the positive (+) post and the black lead to the negative (-) post. Install a 1-amp fuse between the red cable and positive post of your 12-volt battery.

If a fuse panel is available, we recommend wiring the power cable into the fuse panel.

Note: The LCR must be fused separately from any other accessory.

Your Angle-Lock connectors can only be plugged in one way. Position the connector so the letter P or T can be read and the 90-degree bend is pointed downward. Push the connector in as far as it will go. Turn the positive locking ring as far as it will go clockwise until you feel it lock. Locking ring as far as it will go clockwise until you feel it lock. Your connector is now locked into place.

Note: For easy access to the connectors, simply loosen the mounting knobs and tilt your LCR forward. The connectors are now in full view and easy to plug or unplug.

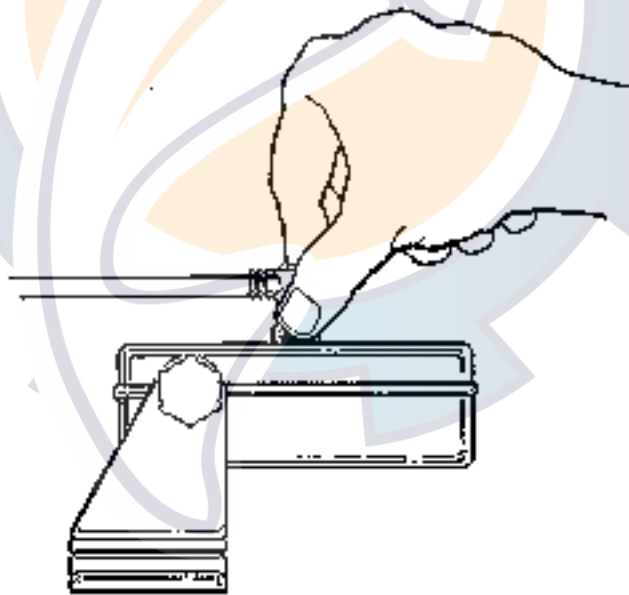

INSTALLATION

TEST THE INSTALLATION

TEST THE INSTALLATION

Testing should be performed with the boat in the water, however you can initially confirm basic operation with the boat trailered.

Press POWER once to turn the unit on. There will be an audible chirp when any button is pressed to confirm the button press. If the unit does not power-up, ensure the unit is fully seated on the mount and that power is available.

The first screen provides four options: Start-up, Options, Simulator, and Diagnostic. A message at the bottom of the screen indicates the transducer connection. If no transducer is detected (or one is not connected), the message will indicate this and the unit will go into simulator after the initial screen times out.

Note: the transducer must be submerged in water for reliable transducer detection.

If a transducer is detected, the unit will enter "Start Up" or normal operation unless you choose another option. If you do not press any button before the timer reaches "0", the normal operation screen is displayed. If the boat is in water, sonar data appears.

If the bottom is visible on screen with a digital depth readout, the unit is working properly. Ensure the boat is in water greater than 2' but less than the depth capability of the unit and the transducer is fully submerged. Remember the sonar signal cannot pass through air.

If the unit is working properly gradually increase the boat speed to test high-speed performance. If the unit-functions well at low speeds but begins to skip or miss the bottom at higher speeds, the transducer requires adjustment. Refer to the appropriate transducer installation section for more detail.

Note: it is often necessary to make several incremental transducer adjustments before optimum high-speed performance is achieved.

Important: For Transom Mount transducer installations, install the third mounting screw after the final transducer adjustments.



USING THE LCR 4000

INTRODUCTION

Before attempting to install or operate your Humminbird LCR, it is recommended that you read the operations manual thoroughly. The LCR is a totally new concept in sonar and has a number of special features not found on any other recorder. To completely understand all the features of your unit, we suggest you follow the instructions set forth in this manual. If after reading the instructions, there is something you do not completely understand about the operations of your unit, we recommend you contact our customer service department- CALL (334)687-0503.

INTRODUCTION

Congratulations on selecting the most advanced piece of sonar equipment ever designed.

Your new Humminbird LCR[®] (Liquid Crystal Recorder) incorporates the most advanced, innovative concepts in sonar equipment. The LCR is probably the most intelligent depth sounder ever created. Advanced microcomputer technology is used to simplify its operation, not complicate it, so you can quickly learn the basics of operating your unit. After a couple of trips on the water, you will be operating your unit like an expert.

Your Humminbird LCR has a number of outstanding features including a unique automatic feature. This computer controlled feature makes using your LCR as easy as pushing the "On" button. The computer will automatically adjust the sensitivity, change the depth scale even if the bottom goes off the screen and black out everything beneath the bottom to make the display easy to read.

Other features include High Visibility LCD readout, night light, low profile swivel mount, waterproof enclosure, four depth ranges beginning with a super-shallow 15 foot depth range, digital bottom reading, and more.

Read this operations manual thoroughly for all the outstanding features of your LCR. You will be amazed at its capabilities.

Since there are virtually no moving parts, your LCR will function more trouble free than any sonar unit you have ever owned.

This unit has been engineered, tested, manufactured, and is guaranteed by the employee/owners of Techsonic Industries, located on the shores of Lake Eufaula, Alabama.

Fishing, boating, and depth sounders are our business, and at Humminbird we stand behind our product 100%.

USING THE LCR 4000

THEORY OF OPERATION

Your new LCR is covered by our Lifetime Guaranteed Service policy. We wish you good luck, good fishing, and many hours of pleasure with your new Humminbird LCR.

THEORY OF OPERATION

Your Humminbird LCR works on the basic principals of sonar.

An electronic signal is generated within the control head of the unit.

When coupled to the transducer, this signal is converted to an ultrasonic signal and is transmitted toward the bottom. The speed of the ultrasonic signal traveling through the waters is approximately 4800 feet per second.

The signal travels through the water until it strikes an object or the bottom. At this instant it is reflected back, picked up by the transducer, reconverted to an electronic signal and is recorded on the display of the LCR.

The reading at the far right hand position of the display illustrates that which is being passed over at that time. If you are familiar with a flasher unit, you might think of the information coming on the right side of the screen as the information that would be seen at one instant on a flasher (see Figure 1). However, unlike a flasher, this information is not lost but it is shifted or moved to the left as new information comes on. Therefore, the information is retained until it disappears from the left hand position of the display.

The display used on the LCR is a Liquid Crystal Display. The material in the display is a liquid that can be aligned such that it either "blocks" light or it lets light pass through. This "blocking" of light is what makes the dots on the screen.

Since the LCR's display depends on light passing through it to make the images, increasing the light source will make it easier to see. This is why your LCR can be seen so well in direct sunlight. You will also notice that the display can be seen better at certain angles. The LCR mounting has been designed for tilting and pivoting so that you can easily maintain a good angle for viewing. Another characteristic of an LCR display is that you may find that some polarized glasses might affect the view by causing a rainbow prism to appear. This condition can possibly be improved by a slight adjustment in tint.

The high visibility readout of the LCR allows you to see fish, bottom contour and underwater structure. Targets as close as three inches apart can be separated on the 15 foot setting.

USING THE LCR 4000

THEORY OF OPERATION

The LCR 4000 is designed to operate with a standard 16° transducer included with the unit. Other transducers, such as 32°, *cannot* be used. In order for your LCR to operate well at high speeds, you must have a *properly mounted transducer*. Please read the transducer mounting procedure carefully.

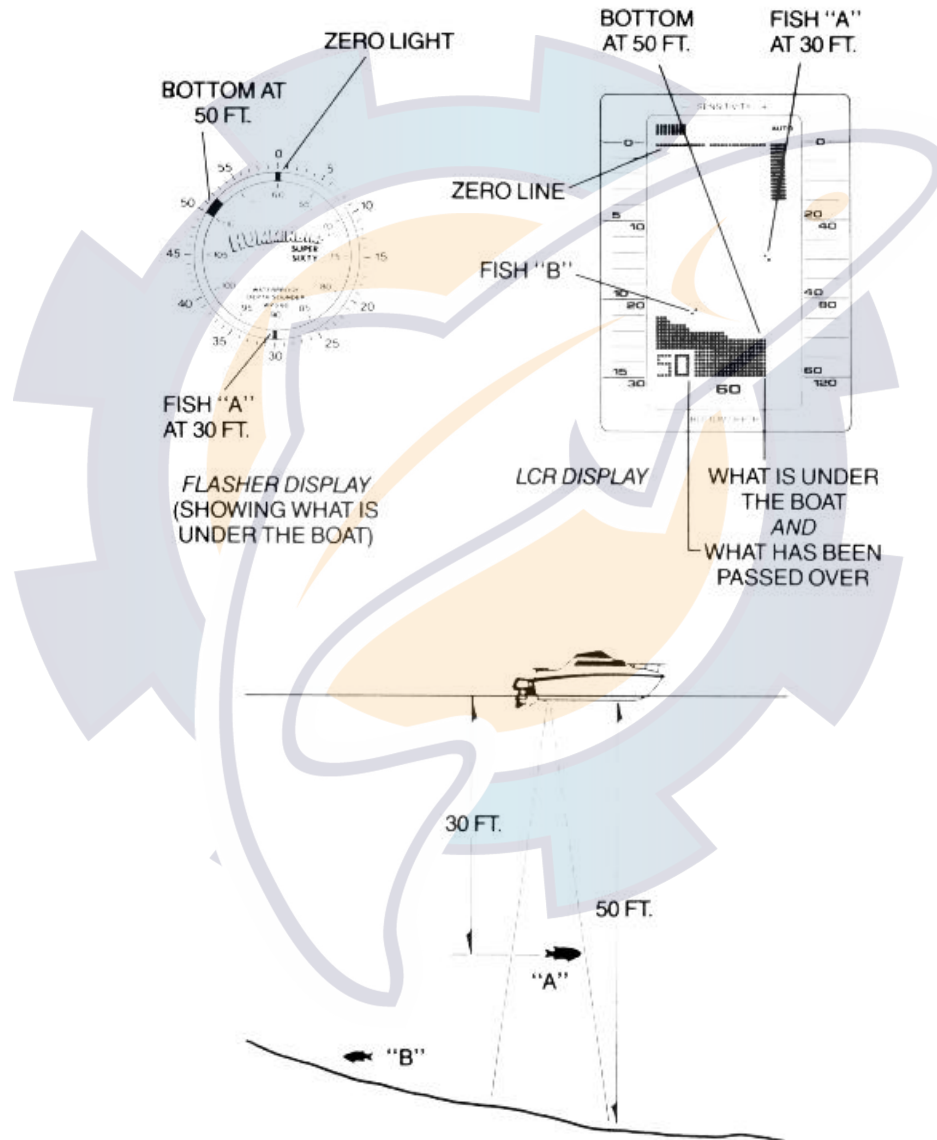

USING THE LCR 4000

TOTAL SCREEN UPDATE

TOTAL SCREEN UPDATE®

What is Total Screen Update?

Total screen update is a unique feature of the LCR4000. It will allow you, when changing depth scales, to totally change or update the screen to the new depth scale. It will allow you to zoom in and look at information in much finer detail even after you've already gone over the area. It will allow you to reverse or bring back information that has gone off the display (up to three full screens).

How Does Total Screen Update Work?

Inside the LCR4000 are memory devices which can store approximately 60,000 bits of information. Automatically, while you're operating the LCR4000, the computer is putting information into the LCR'S memory. This stored information is all the data from zero to 120 feet for four entire screens. All this information (from 0 to 120 ft.) is being recorded no matter what depth scale you're using. Also, the information is being put into memory in much smaller increments (pieces) than is being displayed on the normal 0 to 15, 0 to 30, 0 to 60, or 0 to 120 foot scales. For example, on the 0 to 60 foot scale each dot is equal to one foot of depth, but the computer is putting information into memory such that each dot equals 3 inches.

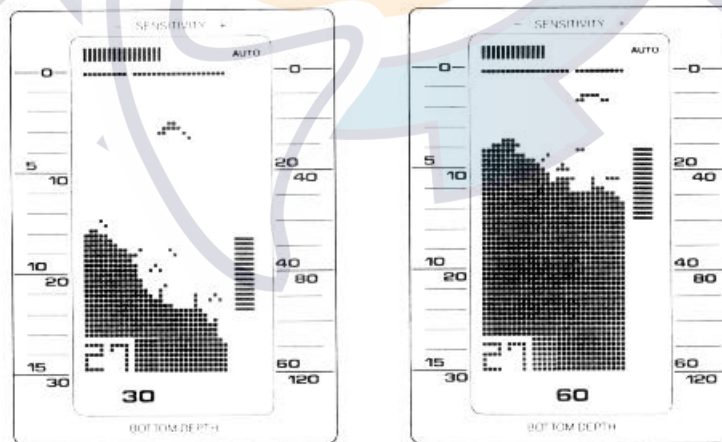

Figure 12

If after reading this, you don't understand all about how the LCR4000's Total Screen Update works, don't worry. The important thing is that you understand how to use Total Screen Update. Read on...

USING THE LCR 4000

TOTAL SCREEN UPDATE

How To Use Total Screen Update

This is the easiest part. Since the LCR's computer is doing all the work, you will find the LCR4000's Total Screen Update very easy to use. There are three ways that you will use Total Screen Update:

1. When changing a depth scale, the LCR's computer will automatically change or update the entire screen to the new depth scale.

In Figure 12 the depth scale is being changed from the 0 to 30 foot scale to the 0 to 60 foot scale.

Note that the display was changed to show the entire screen on the 0 to 60 foot scale.

This Total Screen Update feature works when changing to shallower scales, too. For example, suppose you are in the 0 to 120 foot scale but the bottom depth is only 10 feet. When you change to the 0 to 15 foot scale, the entire screen will look just as if you had gone over the area on the 0 to 15 foot scale.

2. Total Screen Update allows you to reverse or bring back onto the display three full screens past information. This, in effect, multiplies by four the size of the LCR screen. Operation of the reverse function is explained in a later section.

3. The third way that you will use Total Screen Update is in operating the LCR4000's Zoom. Since the computer has stored in memory information from 0 to 120 feet in very small increments, you will be able to recall this information from memory to get an expanded view of areas which you have already passed over.

For example, if you go over some interesting structure or fish, you will be able to zoom in for a better look without going back over the area. Simply activate the zoom and the information that is stored in memory will be recalled and displayed on the screen.

The operation of the zoom function is explained in a later section.

USING THE LCR 4000

OPERATIONAL INSTRUCTIONS

OPERATIONAL INSTRUCTIONS FOR LCR4000

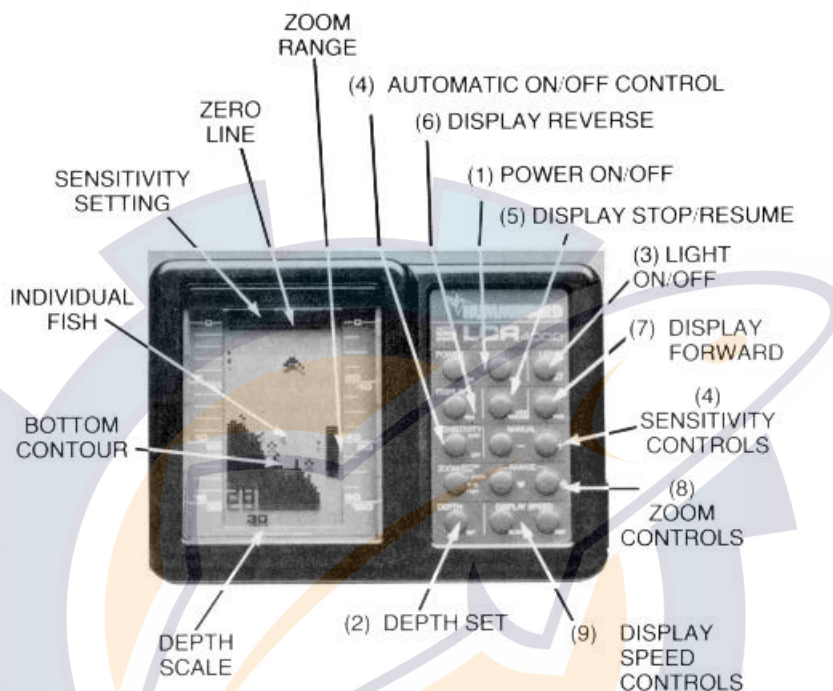

Figure 13

The Humminbird LCR4000 will operate fully automatic or manual at the discretion of the operator. At the heart of the LCR is a microcomputer which is making thousands of decisions every second. With the LCR4000'S automatic features you will quickly and easily learn the basics of operating your unit, and after a couple of trips on the water you'll be operating the LCR4000 like an expert. It is suggested that you familiarize yourself with each of the features and controls prior to operating your LCR4000.

1. **Power:** To activate the unit, depress the power "On" switch. The LCR4000 always comes on in the automatic mode. In the automatic mode, the unit will find the bottom by varying the sensitivity and selecting the proper depth range for a satisfactory return. Also, the display below the bottom is blacked out to make the display easier to read.

To turn the unit off, depress the power "Off" switch.

2. **Depth:** In the automatic mode, the proper depth range is found as soon as the unit is turned on. As you move into deeper water and the bottom goes off the screen, the next deeper range will automatically be activated. Also, as you move into shallower water and the bottom is within about ten dots to the top of the screen, the depth range will automatically change to the next shallower scale.

USING THE LCR 4000

OPERATIONAL INSTRUCTIONS

You may also manually change the depth scale by pressing the depth set button. Each time this button is depressed, the range is decreased by one setting. For example, if you are on the 0-30 ft scale, pressing the depth set button once will change the scale to 0-15 ft. Pressing it again will change the scale to 0-120 ft.

Note: Should you attempt to change a depth scale which is less than the actual bottom depth, the computer will automatically change the depth scale back to the proper position. For example, if you are in 40 feet of water and you change the depth scale to 30 feet, the computer will automatically change back to the 60 foot scale.

Remember, in the manual mode (see paragraph 4 below) the automatic range changer is not active.

The depth range is always displayed at the bottom of the LCR display.

The LCR4000 has four depth ranges, 0-15', 0-30', 0-60', and 0-120'. The graduated depth scales down the left and right of the display will identify the proper depth based upon the range you are on at the time. On the 0-15' scale, each line represents a one foot increment. On the 0-30' scale a two foot increment, on the 0-60' scale, a five foot increment, and on the 0-120' scale, a ten foot increment.

Remember that because of the LCR4000's Total Screen Update feature, information is automatically being put into memory in smaller increments (pieces) than is being displayed on the normal depth scales (see explanation of Total Screen Update earlier in manual). This means, for example, that even though you are in the 0 to 120 ft scale, when you change to the 0 to 15 ft scale the information is displayed just as if you had been on the 0 to 15 ft scale all along. No information or resolution is lost.

3. **Light:** Depress the light "On/Off" switch to activate the display light for night or low light conditions. The light is turned off by again depressing the "On/Off" switch. When using the night light you will notice that the viewing angle, or best viewing position is different than during daylight operation. Tilt the unit back until you find the best angle for night viewing.

4. Sensitivity

Automatic Mode- Each time the unit is turned on, the automatic feature is on. In the automatic mode the sensitivity is adjusted automatically to give a good return and the correct depth range is selected. The word Auto will appear in the upper right hand corner of the display any time the unit is in the automatic mode. The sensitivity bar at the top of the screen will increase or decrease automatically indicating the amount of sensitivity being used. In deeper water or soft bottom conditions this bar will increase,

USING THE LCR 4000

OPERATIONAL INSTRUCTIONS

"AUTO" HAS BEEN TURNED OFF INDICATING MANUAL MODE

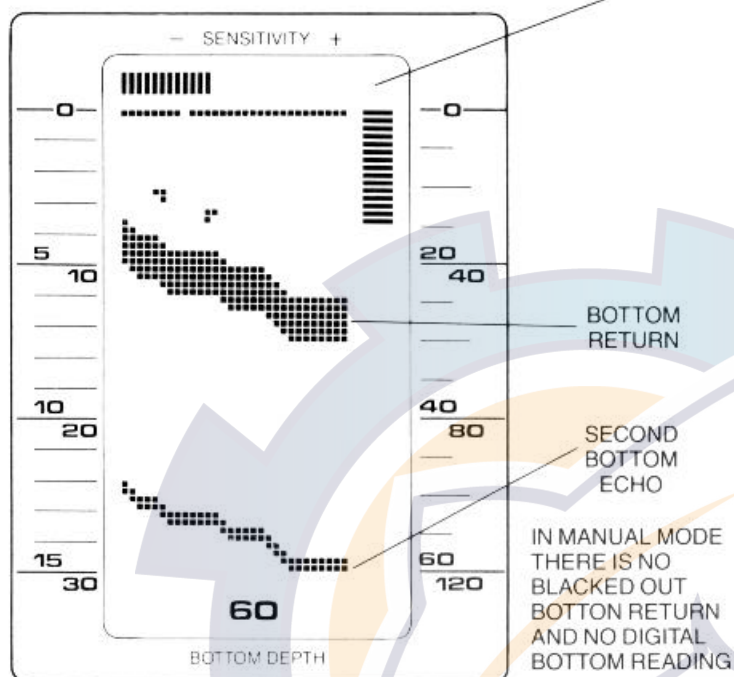

Figure 14

When the (+) or (-) button is pressed once, the sensitivity setting at the top of the screen will change by one division. If the (+) or (-) button is held down the setting will move up or down as long as the button is held down. When the maximum or minimum setting is achieved, the unit will make a "Chirping" sound indicating a limit has been reached.

In the manual mode everything below the bottom is no longer blacked out, therefore a second return or double echo can be displayed if desired. (See Figure 14). Also, the hardness of the bottom can be determined by the thickness of the bottom return. For example, a hard or rock bottom will give a wider bottom return as compared to a soft or muddy bottom. (See Figure 15).

indicating more sensitivity. In shallow water or when a hard bottom is being read, the sensitivity needed to achieve a good return will be less. Also in the automatic mode, the unit will black out the display beneath the bottom line.

Manual Mode- There are two ways of putting the LCR4000 in the manual mode: (1) depress the Auto "On/Off" button or (2) depress either sensitivity decrease (-) or increase (+) button. You will notice that the word Auto in the upper right hand corner of the display has gone off. The operator can control the amount of sensitivity by depressing the (+) or (-) button. There are 15 sensitivity settings.

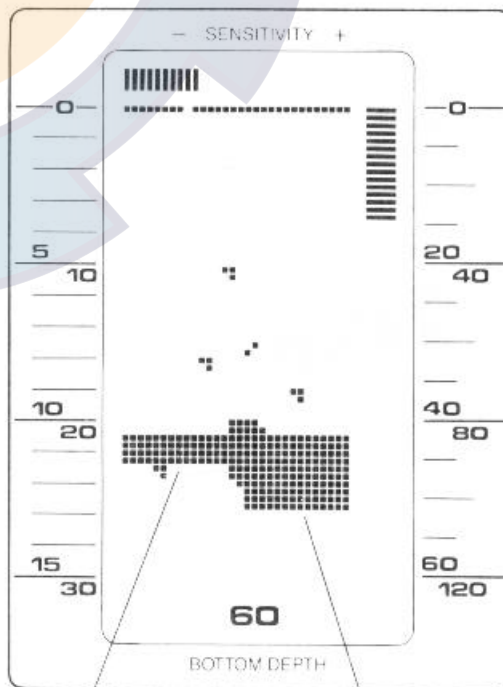

MUDDY OR SOFT BOTTOM

HARD OR ROCKY BOTTOM

Figure 15

USING THE LCR 4000

OPERATIONAL INSTRUCTIONS

Note: You will find the manual sensitivity control more useful when looking for smaller targets such as smaller fish. In the automatic mode the computer might not be using enough sensitivity to show smaller targets. At higher sensitivity more targets will be seen. Therefore, you might want to use the automatic mode while running and then use the manual mode for charting and finding fish.

You should also note that it's possible to have the sensitivity set too high such that reflection off of suspended matter or air bubbles will begin to black out the display.

In the manual mode the depth scale does not change automatically and the digital bottom depth is not displayed. To once again activate the automatic mode, depress the Sensitivity Auto "On/Off" switch.

5. Display: Stop/Resume: Anytime during the operation of the LCR, the operator may "freeze" the display by simply pushing the display "Stop/Resume" button. This feature will aid in the learning and interpretation of the signal on your LCR display by giving you time to study the display. The "Stop/Resume" function will not change any original settings when once again activated. The sensitivity and display speed **cannot be changed while the display is stopped.**

If they are pressed, a chirping sound will indicate that these functions cannot be changed while the display is stopped. All other functions, such as Zoom, Depth Scales, Reverse and Forward, are active with the display stopped. When the "Stop/Resume" button is pressed again the unit will resume reading at the immediate point at which the boat is sitting on the water.

6. Display Reverse: Information that has gone off the display can be reversed back onto the screen by using the Display Reverses feature. By pressing the Reverse button information that had gone off the left side of the display can be seen again, that is, the display will begin to shift to the right. When the Reverse button is pressed once, the display will move one division to the right. If the button is held down the display will move to the right as long as the button is held down.

Up to three full screens may be put back onto the display. Once three screens have been reversed, a chirping sound will indicate that the limit has been reached.

7. Display Forward: This button moves or shifts the display to the left. This means that the Forward button shifts the information in the opposite direction than does the Reverse button.

Therefore, the Reverse button shifts the display to the right, and the Forward button shifts the display to the left.

USING THE LCR 4000

OPERATIONAL INSTRUCTIONS

To begin transmitting and receiving of new information after using Reverse or Forward, simply press the Stop/Resume button. The display will change back to the location seen before reversing and the unit will resume reading at the immediate point at which the boat is sitting in the water.

8. Zoom and Bottom Lock: You will find the Zoom feature of the LCR4000 to be a very valuable tool. The Zoom Range is controlled by the Range Up or Range Down buttons. Each time one of these buttons is depressed the zoom region will move one division. If the button is held down the region will continue to move as long as the button is held down.

The Zoom Region is indicated by the group of bars at the extreme right of the display. This region is 7 ½ feet on the 0 to 15 ft and 0 to 30 ft scales and is 15 ft on the 0 to 60 ft and 0 to 120 ft scales. This means that when zooming in on the 15 ft or 30 ft scales each dot is 1 ½ inches, and on the 60 ft or 120 ft scale each dot is 3 inches.

What Zoom Does

The zoom feature on the LCR4000 will allow you to look at underwater readings in very fine detail and with the LCR4000's Total Screen Update you have the capability to zoom in on bottom, fish and structure, even after you have gone over the area.

How To Use Zoom

First position the Zoom Region (See Figure 16) next to the area that you want to expand by pressing the Range up or down button. Next, by pressing the Zoom On/Off button the Zoom will be activated. You will notice that the letter Z appears in the lower right hand corner of the display, indicating that the Zoom is on. You will also notice that the entire screen

has been changed to show an expanded view of the area from the top of the Zoom Range to the bottom of the Zoom Range. The LCR4000'S Total Screen Update feature allows you to zoom in on an area even after you have passed over it. Figure 16 shows two screens, one with Zoom off and one after turning Zoom on.

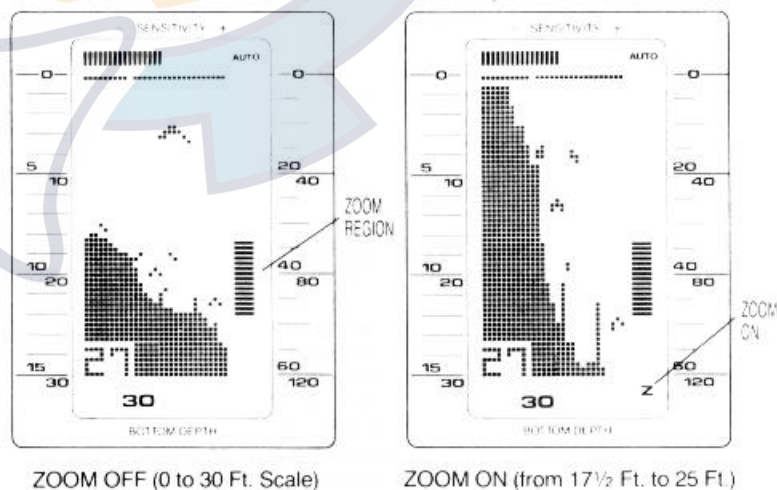

USING THE LCR 4000

OPERATIONAL INSTRUCTIONS

The Zoom may be activated at any time (during normal transmitting and receiving or stop action, or reverse), but while learning to use the Zoom feature you might find it easiest to first press the Stop/Resume button to freeze the display. Now you can position the Zoom Range, activate the Zoom, and study the display. By pressing the Zoom On/Off button again you can go back to the un-expanded or normal display. Going back and forth several times will help you in understanding exactly what you are seeing with the Zoom activated.

Some Additional Things You Should Know About Zoom

- A. While the Zoom is turned on you can move the Zoom Range up and down. This will allow you to search or look at an entire area in fine detail.
- B. You can also zoom in on information that has gone off the screen by pressing the reverse button. This can be done by either reversing and then activating the Zoom or by activating the Zoom and then reversing. See Section 6 for reversing instructions.
- C. The Zoom Range indication at the right of the display can be used for depth reference. For example in Figure 15 the Zoom Range is set between 17 ½ feet and 25 feet. This means that when the Zoom is activated that you are looking at an expanded view of the area from 17 ½ feet to 25 feet.
- D. While the Zoom is turned on, you cannot change Sensitivity, Depth Scale, or Display Speed. If you press any of these buttons while Zoom is on, a chirping sound will occur indicating an incorrect entry.
- E. Using the Zoom you can actually have a 0 to 7 ½ foot scale on your LCR4000. To do this, first position the Zoom Range as far up as it will go on the 0 to 15 ft scale. Now turn on Zoom. The full screen is now a 0 to 7 ½ foot scale.
- F. Remember that because of the LCR4000's Total Screen Update feature the information from 0 to 120 feet is always being recorded in memory. This means that even while you are using Zoom, no information is being lost. You can turn Zoom off, go to any depth scale and see all the information just as if you had been on that depth scale all along.

Bottom Lock:

Your LCR4000 has a very unique bottom lock feature. To activate bottom lock, hold down the zoom on/off button for 1 to 2 seconds. The "Z" in the lower right of the display will come on indicating that it is activated. Bottom lock works very similar to zoom except that the zoom region always stays on the bottom, therefore giving an expanded view from the bottom up. You will notice that as the bottom depth changes, the zoom cursor will change to maintain its position on the bottom

USING THE LCR 4000

OPERATIONAL INSTRUCTIONS

In bottom lock the expanded information always comes onto the screen at the same location. However, as the information moves across the screen and as the bottom contour moves up or down, the displayed information will also move so that you can see the actual bottom contour. Remember, in bottom lock, the bottom always comes on the screen at the same location but then as it moves across the screen it will move up or down as the bottom contour changes.

When the bottom lock is activated, the LCR4000 will change to the 120 foot scale, so that the bottom can always be tracked.

9. **Display Speed:** The LCR4000 has a total of eight display speeds. When the unit is turned on the display will be advancing at a medium speed. To increase the display speed, depress the "Fast" button once or hold it down to change rapidly. An audible sound is heard each time the speed is advanced. When the limit has been reached a chirping sound will be heard. At this point the speed will be advancing at its maximum. To decrease the speed, simply depress the "Slow" button until the desired advance is reached.

The speed of the boat and the display speed will have a large effect on the way information is displayed. You should select the fastest display speed for high speed operation, but use a slower display speed for idle or trolling speed.

10. **Digital Bottom Reading:** The digital bottom reading is displayed in the lower left area of the screen. This digital reading will operate while the unit is in the automatic mode, on any depth scale or with zoom or bottom lock activated. **The digital bottom reading will not be seen while in the manual mode.**

USING THE LCR 4000

ADDITIONAL INFORMATION

Some additional things you should know about the LCR4000.

- Some polarized glasses might affect your view of the LCR display. It could result in a prism or rainbow effect. This condition can possibly be improved by a slight adjustment in tilt.
- *If you get confused* while in the manual mode, for instance, if you don't know where the bottom is, then press the auto on/off button to turn on the automatic mode. The LCR4000 will find the bottom by selecting the proper sensitivity level and depth scale. You can then go back to the manual mode if desired.
- In order for your LCR to operate well at high speeds, you must have a *properly mounted transducer*. Please read the transducer mounting procedure carefully.
- The transducer for the LCR4000 is a 16° just like most standard Humminbird flasher units. Other transducers, such as 32°, *cannot* be used.

Caring For Your LCR:

Since your Humminbird LCR is completely waterproof, it can be cleaned with soap and water or hosed off after salt water use with no fear of damage to the unit or its electronics. When cleaning the lens, it is suggested you use a chamois cloth and a non-abrasive cleaner such as Windex. Do not wipe while dirt or other gritty material is on the lens. **Care should be exercised to avoid scratching the lens.** Keep chemicals such as bug repellent, ammonia or gasoline away from the LCR case and lens.

As with any electrical instrument, do not leave your LCR on the dash board or rear window area of the car. The sun can create extremely high temperatures which can damage the case and internal electrical components. During extended periods of non-use, such as winter, you should store the LCR and other removable depth sounders in the house or garage. This will help prolong the good appearance and operation of these instruments.

USING THE LCR 4000

LEARNING TO USE YOUR LCR

LEARNING TO USE YOUR LCR

After installing the unit, transducer, and power cable as instructed, the LCR is ready for use. By following the steps below you will be able to quickly learn how to use the LCR. Also, trouble shooting suggestions are listed in these steps. Note: Perform steps 1 through 7 at idle or slow speed. These steps will insure that your LCR is working properly.

Step 1

Turn your LCR on by pushing the "On" button. The LCR'S computer will automatically adjust the sensitivity and depth scale so that in about one second you will see images appear on the right side of the display and moving to the left. The small gap in the zero line allows you to see movement on the display even when the bottom is not changing.

TROUBLE SHOOTING: If nothing happens when the "On" button is pushed, check your electrical connections and fuse. Also check that the red wire on the power cable is connected to the positive battery terminal and that the black wire is connected to the negative battery terminal. If these wires are reversed it will not damage the LCR.

It is normal if when reversing the boat, the bottom return is lost, since air from the prop is being forced under the transducer. Remember the transducer cannot transmit through air.

TROUBLE SHOOTING: If the display comes on when the "On" button is pushed but no bottom information is seen, check that the transducer connector is securely locked to the rear of the LCR. Also insure that the transducer is completely submerged. A transducer cannot work properly in air or through air bubbles in the water.

Step 2

Still moving at a slow speed, begin going toward deeper water. You will see that the LCR will display changes as small as 3 inches on the 0-15 foot scale. Continue to move into deeper water until the bottom return moves off the display. The LCR will automatically change to the next deeper depth scale (indicated at bottom of the display). Notice that the entire screen is changed to the new depth scale. This is the Total Screen Update feature.

USING THE LCR 4000

LEARNING TO USE YOUR LCR

Step 3

Press the depth set button once to change to the next lowest scale. If the bottom is deeper than this scale, the computer will automatically change back to the proper scale. By pressing the depth set button three or four times you will see that the depth scale will change down to the 0 to 15 foot scale and then to the 0 to 120 foot scale. Next change to the 0 to 15 foot scale. If the water is deeper than 15 feet, the depth scale will change to the correct scale.

Step 4

Press the Stop/Resume button to lock the display. Move the Zoom Range down by holding down the button and position it down to the bottom of the water. Next, activate the Zoom by pressing the Zoom On/Off button. You will see that the entire screen has changed to give you a much more detailed view. Press the Zoom on/off button a few times to go back and forth so that you can get a better understanding of exactly what you are seeing. (You do not have to stop the display to use Zoom, but at first it is probably easier to learn this way).

With Zoom on, move the Zoom Range up and down. This is how you can search up and down an entire area.

Step 5

Turn the Zoom off. Press and hold down the Reverse button to bring information back onto the screen. As much as three full screens may be reversed. Pressing the Forward button moves the information back to the left. You can also zoom in on the information being reversed.

Step 6

Press the Stop/Resume button to begin normal transmitting and receiving.

Step 7

Press the Auto Sensitivity On/Off button to change to the manual mode. Notice that the word AUTO in the upper right hand corner of the display has gone off. Also, the area below the bottom is no longer blacked out. You can now change the sensitivity setting by pressing the increase + or decrease - buttons. Notice that the digital bottom reading goes off in the manual mode. Note: in the manual mode the depth scales will not automatically change. The automatic depth change works only in the automatic mode.

USING THE LCR 4000

LEARNING TO USE YOUR LCR

Step 8

Steps 1 through 7 have verified that your LCR is working properly. You are now ready to increase boat speed **to test the transducer installation**. As you increase boat speed the LCR should give a continuous bottom return. With a proper transducer installation your LCR will perform well at speeds over 75mph.

TROUBLE SHOOTING: If at high speeds the bottom return is not continuous or there are gaps in the bottom, then the transducer installation or location is such that air is going under the transducer face. Remember that a transducer cannot work properly through air or through air bubbles in the water. Refer back to the transducer mounting procedure for adjustments or for the other mounting options.

TROUBLE SHOOTING: If when making a hard turn, the bottom reading is lost, it is the result of the transducer coming out of the water during the turn.

LEARNING TO READ THE DISPLAY

The following illustrations show some typical display with bottom, structure, and target returns. These should help you in interpreting the information being displayed on your LCR.

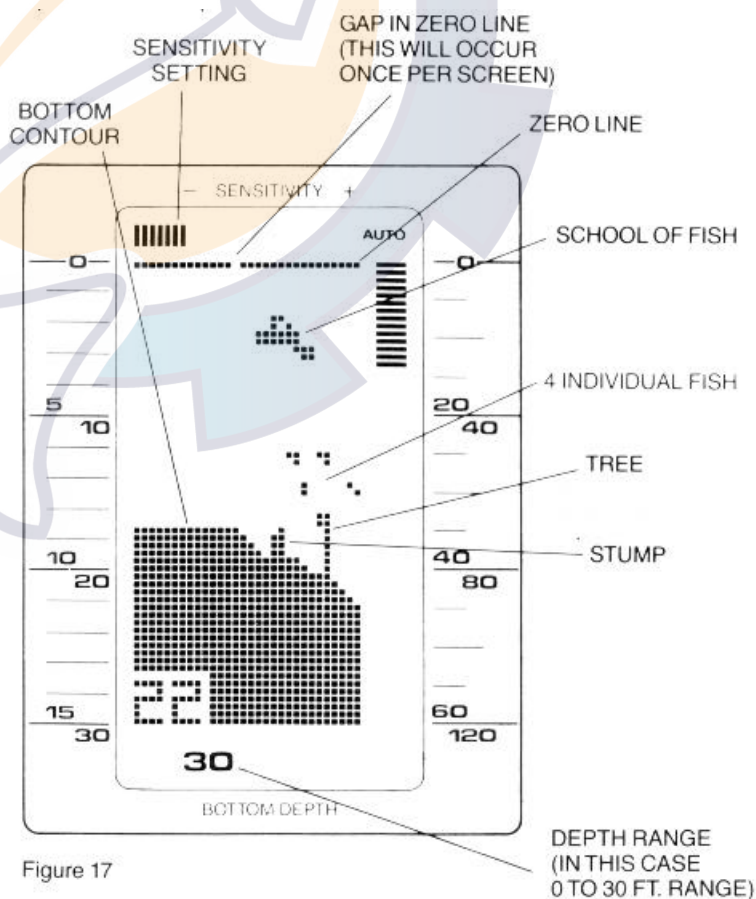
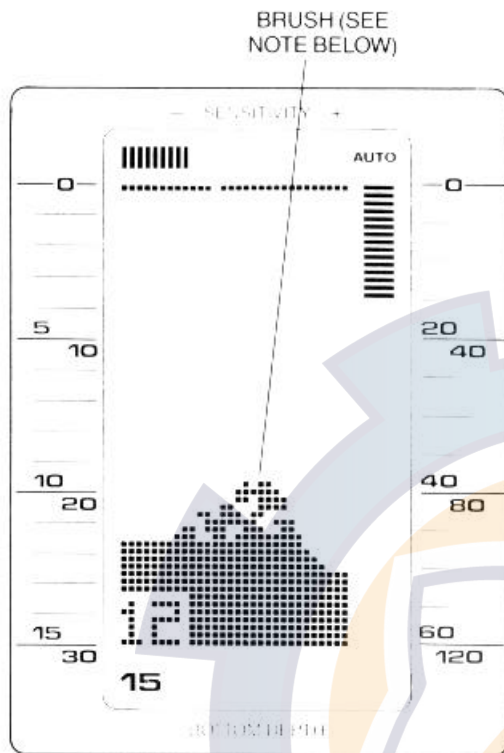

Figure 17

USING THE LCR 4000

LEARNING TO READ THE DISPLAY



Brush or thick standing timber will appear as a thick mass with holes or gaps as shown above.

Figure 18

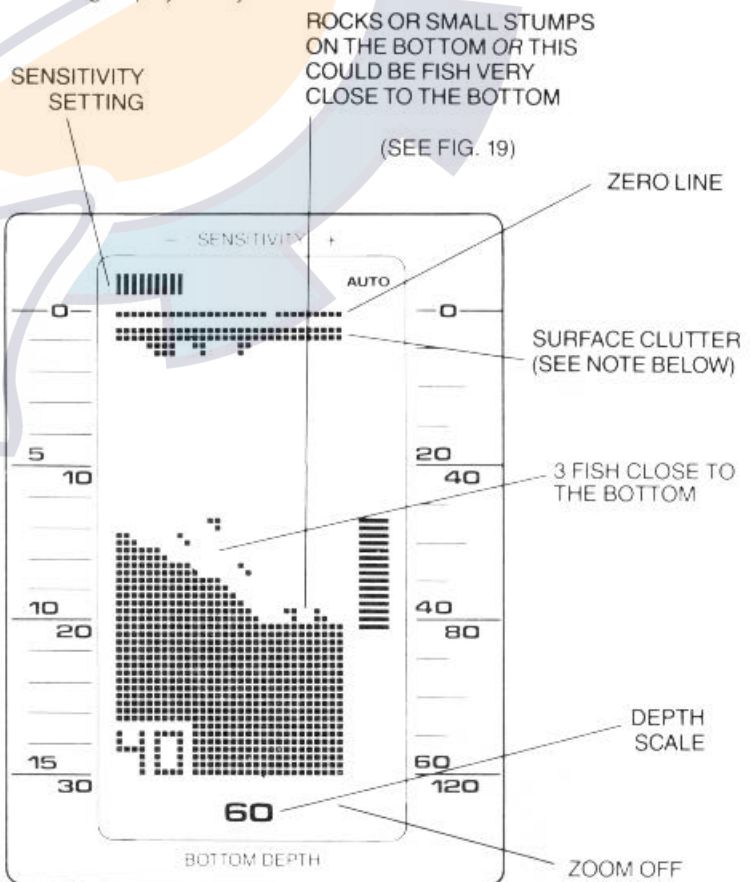

Surface clutter: The STC in your LCR will normally eliminate surface clutter, however, in some water conditions or when going across the wake of a boat the surface clutter will appear as shown above.

Figure 18A

USING THE LCR 4000

LEARNING TO READ THE DISPLAY

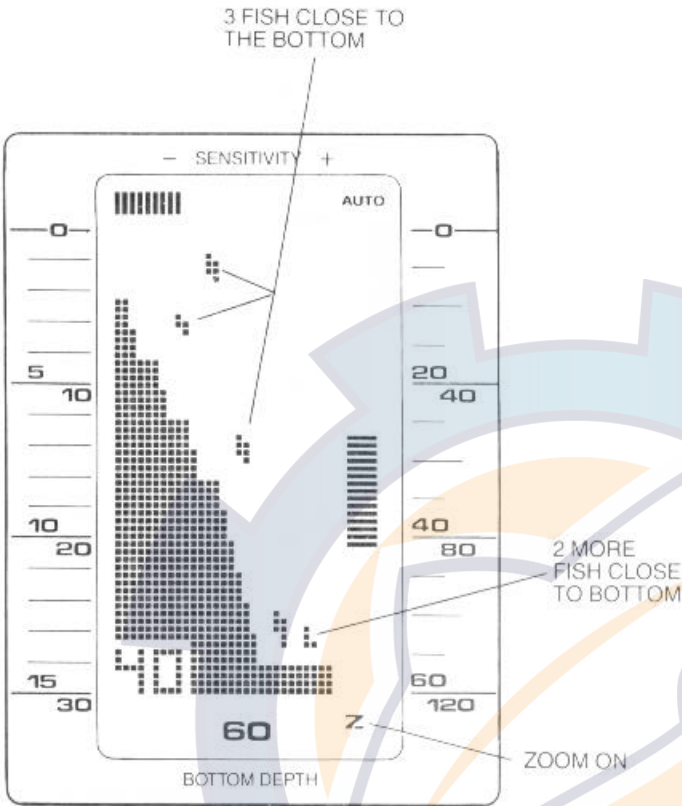

With Zoom activated the two objects close to the bottom on 0-60 ft scale can now be seen as fish off the bottom.

Thermocline is a temperature change at a certain depth in the water. In some conditions the sonar waves will actually reflect or bounce off this temperature change and therefore it will be displayed on the LCR as shown above. To see the thermocline, you will need to go to the manual mode and increase the sensitivity setting.

One of the best ways to learn to use your LCR is to go over familiar locations. If you know what's under the water and can see it displayed on the LCR then you're on your way toward gaining the experience you need.

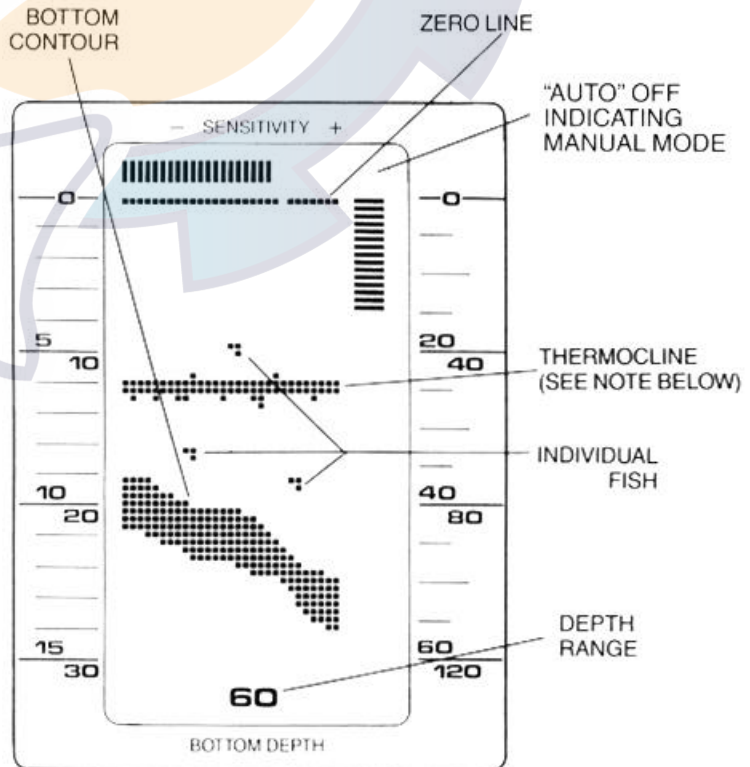

MAINTENANCE AND WARRANTY

MAINTENANCE

MAINTENANCE

Your Humminbird fishfinder is designed to provide years of trouble free operation with virtually no maintenance. Follow these simple procedures to ensure your Humminbird continues to deliver top performance.

- If the unit comes into contact with salt spray simply wipe the affected surfaces with a cloth dampened in fresh water. Do not use a chemical glass cleaner on the lens. Chemicals in the solution may cause cracking in the lens of the unit.
- When cleaning the LCD protective lens, use a chamois and non-abrasive, mild cleaner. Do not wipe while dirt or grease is on the lens. Be careful to avoid scratching the lens.
- If your boat remains in the water for long periods of time, algae and other marine growth can reduce the effectiveness of the transducer. Periodically clean the face of the transducer with liquid detergent. Pivoting the transducer up in the bracket may allow better access for inspection or cleaning.
- If your boat remains out of the water for a long period of time, it may take some time to wet the transducer when returned to the water. Small air bubbles can climb to the surface of the transducer and interfere with proper operation. These bubbles dissipate with time, or you can wipe the face of the transducer with your fingers after the transducer is in the water.
- Never leave the fishfinder in a closed car or trunk - the extremely high temperatures generated in hot weather can damage the electronics.

MAINTENANCE AND WARRANTY

TROUBLESHOOTING

TROUBLESHOOTING

Do not attempt to repair the fishfinder yourself. There are no user serviceable parts inside, and special tools and techniques are required for reassembly to ensure the waterproof integrity of the housing. Repairs should be performed only by authorized Humminbird technicians.

Many requests for repair received by Humminbird involve units that do not actually need repair. These units are returned "no problem found." If you have a problem with your Humminbird, use the following troubleshooting guide before calling Customer Support or sending your unit in for repair. Your Humminbird fishfinder contains several tools that can aid in determining if there is a problem and how to isolate and repair the problem in many cases.

1. Nothing happens when I turn the unit on.

Check the power cable connection at both ends. Be sure the cable is connected correctly to a reliable power source - red lead to positive, black lead to negative or ground. Ensure the power available at the mount is between 10 and 20 VDC. If the unit is wired through a fuse panel, ensure the panel is powered. Often accessory fuse panels are controlled by a separate switch or the ignition switch. Also, often a fuse can appear to be good when in fact it is not. Check the fuse with a tester or replace it with a fuse known to be good.

Check the power connection to the unit. It is possible to force the power cable connector into the cable holder incorrectly. If the connector is reversed, the unit will not work. Examine the contacts on the back of the unit to ensure there is no corrosion. Finally, ensure the unit is firmly seated on the mount. The electrical contacts are not made until the unit is fully seated.

Ensure the metal cable retainer is properly installed in the mount. If not, the power connected may push out when the unit is put on the mount.

2. There is no transducer detected.

Most Humminbird fishfinders have the ability to detect and identify that a transducer is connected. If at power up, a message indicates "transducer not connected," only simulator operation is possible. First, ensure that an appropriate transducer connector is positioned correctly in the connector holder, and that the unit is fully seated on the mount. Your Humminbird fishfinder will work only with an appropriate transducer; check the accessory guide for compatibility.

MAINTENANCE AND WARRANTY

TROUBLESHOOTING

Second, inspect the transducer cable from end to end for breaks, kinks, or cuts in the outer casing of the cable. Also ensure the transducer is fully submerged in water. If the transducer is connected to the unit through a switch, temporarily connect it directly to the unit and try again. If none of these items identifies an obvious problem, the transducer itself is probably the problem. Be sure to include the transducer if returning the unit for repair.

3. There is no bottom reading visible on the display.

There are a number of possible causes for this condition. If the loss of bottom information occurs only at high boat speeds, the transducer needs adjusting. If the digital depth readout is working but there is no bottom visible on-screen, it is possible the depth range has been adjusted manually to a range lower than what is needed to display the bottom. Also, in very deep water, it may be necessary to manually increase the sensitivity setting to maintain a graphic depiction of the bottom.

If you are using a transducer switch to connect two transducers to the unit, ensure the switch is in the correct position to connect a transducer that is in water. (If a trolling motor transducer is selected and the trolling motor is out of water, no sonar information appears.)

If none of the above solve the problem, inspect the transducer cable from end to end for breaks, kinks, or cuts in the outer casing of the cable. If the transducer is connected to the unit through a switch, temporarily connect it directly to the unit and try again. If none of these items identifies an obvious problem, the transducer itself may be the problem. Be sure to include the transducer if returning the unit for repair.

4. When in very shallow water, I get gaps in the bottom reading and inconsistent digital depth indication.

Your Humminbird fishfinder will work reliably in water 2' (.6m) or deeper. The depth is measured from the transducer, not necessarily from the surface.

MAINTENANCE AND WARRANTY

TROUBLESHOOTING

5. The unit comes on before I press POWER, and won't turn off.

Check the transducer cable. If the outer jacket of the cable has been cut and the cable is in contact with bare metal, you need to repair the cut with electrical tape. If there is no problem with the cable, disconnect the transducer from the unit and see if the problem is corrected, to confirm the source of the problem.

6. I get gaps in the reading at high speeds.

Your transducer needs adjusting. If the transducer is transom-mounted, there are two adjustments available to you - height and running angle. Make small adjustments and run the boat at high speeds to determine the effect. It may take several tries to optimize high speed operation. This can also be a result of air or turbulence in the transducer location caused by rivets, ribs, etc.

7. My unit loses power at high speeds.

Most Humminbird fishfinders have over-voltage protection that turns the unit off when input voltage exceeds 20 VDC. Some outboard motors do not effectively regulate the power output of the engine's alternator and can produce voltage in excess of 20 volts when running at high RPMs. Your fishfinder displays input voltage in the Diagnostic screen. Use this readout to determine if the voltage exceeds 20 VDC.

8. The screen begins to fadeout. Images are not as sharp as normal.

Check the input voltage using Diagnostic. The fishfinder will not operate on input voltages below 10 VDC.

9. The display shows many black dots at high speeds and high sensitivity settings.

You are seeing noise or interference caused by one of several sources. Noise can be caused by other electronic devices. Turn off any nearby electronics and see if the problem goes away. Noise can also be caused by the engine. If engine noise is causing the interference, the problem will intensify at higher RPMs. Increase the engine speed with the boat stationary to isolate this cause. Propeller cavitation can appear as noise on-screen. If the transducer is mounted too close to the propeller, the turbulence generated can interfere with the sonar signal. Ensure that the transducer is mounted at least 15" (38cm) from the prop.

MAINTENANCE AND WARRANTY

WARRANTY

HUMMINBIRD ONE YEAR FULL WARRANTY

First year repairs (from original date of purchase) on your Humminbird fishfinder are absolutely free. This does not include physical damage to the unit or its accessory items. Any modification or attempt to repair the original equipment or accessories by unauthorized individuals will void the warranty. Return the warranty registration card and retain your bill of sale for warranty verification. Accessories not manufactured under the Humminbird trade name are not covered by our warranty. **The customer is responsible for shipping charges to Humminbird.** Humminbird will provide ground UPS or Parcel Post shipping back to the customer free of charge. This warranty applies to the original purchaser only.

This warranty is in lieu of all other warranties expressed or implied and no representatives or persons are authorized to provide for any other liability in connection with the sale of our products. Humminbird reserves the right to perform modifications or improvement on its products without incurring the obligation to install the changes on units previously manufactured, sold, delivered, or serviced.

THIS IS A FULL WARRANTY AS DEFINED BY THE FEDERAL WARRANTY ACT EFFECTIVE JULY 4 1975.

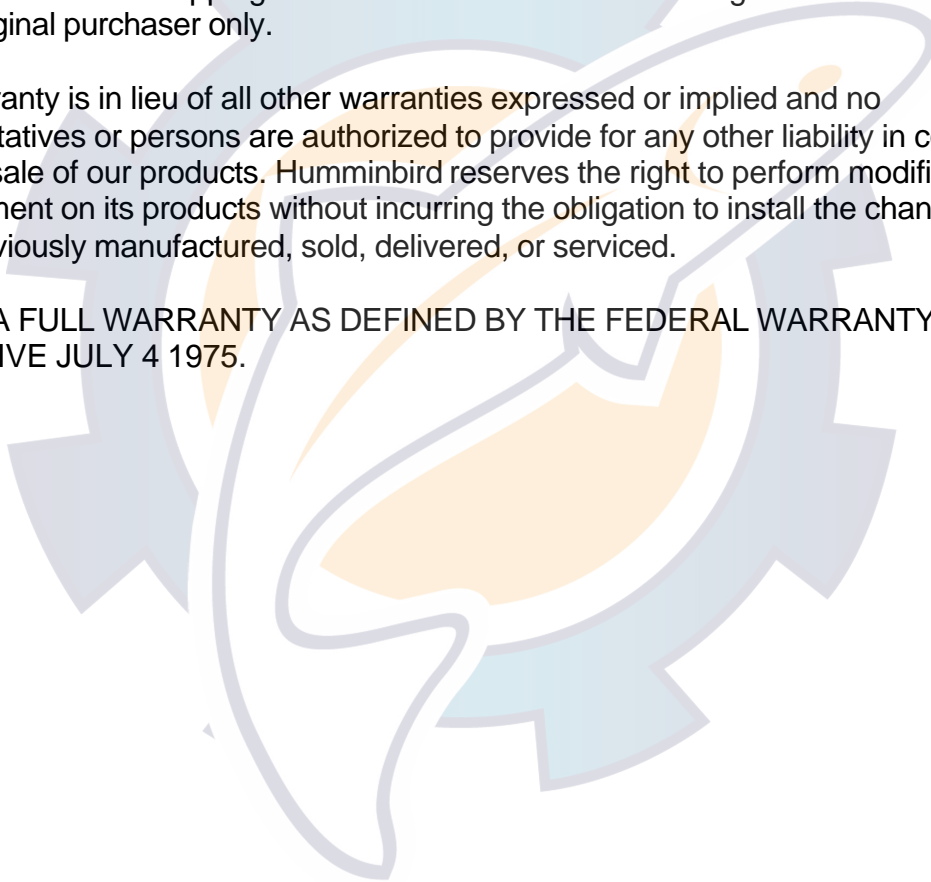

MAINTENANCE AND WARRANTY

SERVICE POLICY

SERVICE POLICY

This Service Policy is valid in the United States only. This applies to Humminbird units returned to our factory in Eufaula, Alabama, and is subject to change without notice.

All repair work is performed by factory-trained technicians to meet exacting factory specifications. Factory serviced units go through the same rigorous testing and quality control inspection as new production units.

Even though you'll probably never need to take advantage of our incredible service guarantee, it's good to know that we back our unit this well. We do it because you deserve the best. We will make every effort to repair your unit within three working days from the receipt of your unit. This does not include shipping time to and from our factory. Units received on Friday are usually shipped by Wednesday, units received Monday are usually shipped by Thursday, etc.

We reserve the right to deem any product unserviceable when replacement parts are no longer reasonably available or impossible to obtain.

After the original warranty period, a standard flat rate service charge will be assessed for each repair (physical damage and missing parts are not included). Please call our Customer Support Department to verify the service charge for your unit.

The standard service charge includes UPS or Parcel Post freight only. If charges are not prepaid, the unit will be returned COD. If you are experiencing problems related to bottom or depth readings please send your transducer along with your unit when sending for repair.

MAINTENANCE AND WARRANTY

CUSTOMER SUPPORT

CUSTOMER SUPPORT

If you have any questions, call our
Humminbird Customer Support Hotline: **1-334-687-0503**

Throughout the U.S. and Canada, hours are Monday-Friday, 8:00 a.m. to 5:00 p.m.
Central time.

If after reading "Troubleshooting" you determine your unit needs factory service, please
attach a description of the problem and send it with the unit to the address below.

If you are including a check please attach it to the unit.

**Humminbird
Service Department
Three Humminbird Lane
Eufaula, AL 36027
USA**

